

# AP-MULTIMAX MIMO

## The Perfect All-In-One Solution for your In-Vehicle Mobile Access Router



Available colors: Black  or White

**The AP- MultiMax MIMO Antenna** is the all-in-one, low profile housing that provides 2 high gain Multiple-In, Multiple-Out (MIMO) Cellular/LTE antennas, 1 high gain WiFi antenna (802.11 abgn,ac), and a GPS antenna. This can come with a threaded bolt mount, permanent adhesive mount or magnetic mount; color choices of black or white.

### Key Benefits:

**Faster Data Speeds.** With the AP-MultiMax MIMO Antenna, you will get superior Cellular/LTE data throughput speeds with the Multiple-In, Multiple-Out dual antennas. Our double Cellular/LTE antenna design takes advantage of the fastest speeds that the 4G/LTE network offers. Top WiFi speeds are achieved with our Single-WiFi antenna to off-load large amounts of data or to push software updates to your computer from your WiFi hotspot.

**GNSS Location Technology:** GPS just got better. When used with a GPS receiver with GNSS capabilities and dead reckoning, the GPS antenna can access 4 different satellite constellations (GPS, GLONASS, Galileo and Beidou), utilizing up to 48 satellites. This provides better accuracy, faster time to first fix to acquire a satellite, as well as superior coverage in rural areas as well as dense downtown urban zones with skyscrapers.

### Airgain, Inc.

8350 E. Evans Road, Suite D-2, Scottsdale, AZ 85260  
Phone: 480.657.7354 | Fax: 480.657.0204 | AP-orders@airgain.com

Copyright 2017 Airgain, Inc. : Version 6a (06/05/17)

**Bigger Wireless Footprint:** By using AP-MultiMax MIMO Antenna, you can be farther away from a cell site or WiFi hotspot and still connect; up to 25% more wireless coverage, depending on the geography you travel in.

**One Simple Installation:** All antennas are built into one physical housing so that you only have to drill one hole for a fast and tidy installation. This reduces the need for multiple antennas on top of the vehicle.

**Long Product Life:** Our rugged, low profile design gives you protection against all of the natural hazards a vehicle faces including vibration, hot, cold, ice, salt, dirt, car washes, and tree branch sweeps. Our antennas typically outlast the life of vehicle.

**Connects to mobile data wireless routers with TWO Cellular/LTE ports, ONE WiFi port and a GPS port.**

Product	Cell/LTE Antenna	WiFi Antenna	GPS Antenna
AP-CCWG	✓✓	✓	✓



# AP-MULTIMAX MIMO

## Electrical Specifications

### Frequencies:

Cellular/LTE = 698-2700 MHz  
 (includes Band 14 LTE)  
 WiFi = 2.4 & 5 GHz (802.11 a,b,g,n, ac)  
 GPS = 1575.42 MHz - 1602 MHz

**VSWR:** 1.5:1 or less at resonant point

**Gain:** 698-890 MHz: 3 dBi;  
 1710-2700 MHz: 4 dBi

### Radiation Pattern:

OMNI Directional  
 Hemispherical (GPS)

### Polarization:

Vertical

## Mechanical Specifications

### Radome:

Glass Filled Polypropylene

### Cable Length:

15 feet (4.5 m) (Adhesive and Bolt Mount)  
 10 feet (3 m) (Magnet Mount)  
 Optional cable length to 35 feet

### Connectors:

The AP-Double Cell/LTE~Quad WiFi~GPS Antenna can come with any RF connectors you need to connect to your modem.

## Environmental Specifications

### RoHS Compliant

**Temperature:** - 40 °C to 85 °C (- 40 °F to +185 °F)  
 operating and storage

**Humidity:** (non-condensing) - 5% to 95%  
 operating and storage

**Military Spec** MIL-STD 810 conformance to thermal, mechanical shock, and humidity.

## GPS Antenna Specifications

Frequency Range . . . . . 1575.42 MHz - 1602 MHz  
 Gain . . . . . 28 dB min.  
 Polarization . . . . . R.H.C.P.  
 (Right Hand Circular Polarization)  
 Noise Figure . . . . . 2.0 max.  
 Aerial Ratio . . . . . 3 dB max.  
 Bandwidth . . . . . 2 MHz min.  
 VSWR . . . . . 2.0 max.  
 Output Impedance . . . . . 50 Ohms  
 Voltage . . . . . 2.7-5.6 Volts  
 Current . . . . . 10 mA ± 0.8 mA

## Dimensions

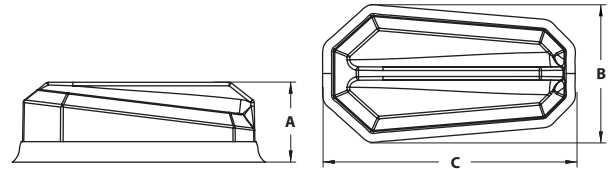

A	B	C
2.220" (56.4 mm)	3.831" (97.3 mm)	7.000" (177.8 mm)

## Built-in Metal Ground Plane

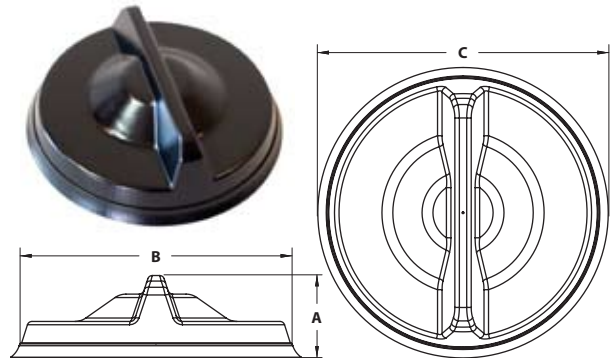

A	B	C
2.183" (55.5 mm)	7.074" (179.7 mm)	7.650" (194.3 mm)

## Mounting Styles

